

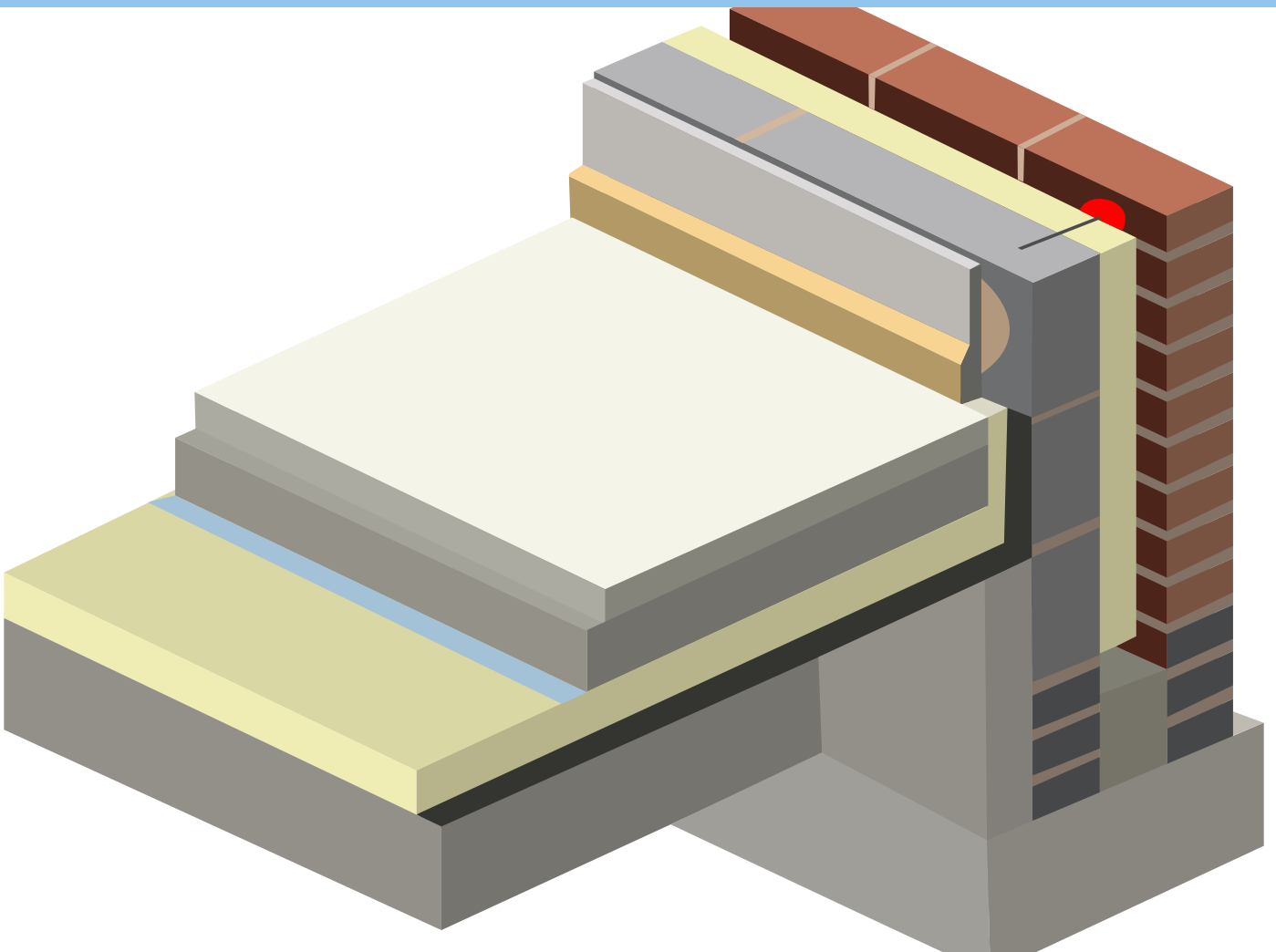

Insulation Manufacturers Association

Best Practice Guide No. 3:

Design and installation guidelines
for PIR floor insulation



Published May 2020

This is one of a series of best practice guides produced by IMA for the benefit of designers and installers and their customers.

Insulation Manufacturers Association (IMA) is the Trade Association that represents both the polyisocyanurate (PIR) and polyurethane (PUR) insulation industry in the UK. Its members manufacture rigid insulation that provides around 40 per cent of the total thermal insulation market into the UK. IMA's membership comprises all of the major companies in the industry, including manufacturers of finished PIR and PUR insulation products, as well as suppliers of raw materials and associated services.

IMA represents the industry's views across all government and industry stakeholders and decision makers and promotes a positive and dynamic business environment for the PIR and PUR insulation industry in the UK.

Published by :



Registered Office:
Units 10-12 County End Business Centre
Jackson Street
Oldham, OL4 4TZ

www.insulationmanufacturers.org.uk

© IMA May 2020

IMA and any contributors believe that the guidance and information contained in this best practice guide is correct. All parties must rely on their own skill and judgement when making use of it. Neither IMA nor any contributor assumes any liability to anyone for any loss or damage caused by any error or omission in this guide, whether such error or omission is the result of negligence or any other cause. Where reference is made to legislation, it is not to be considered as legal advice. Any and all such liability is disclaimed.

Contents

Introduction	4
Floor insulation types	4
Design considerations	5
General	5
U-values	5
Perimeter area ratio (P/A)	5
Under floor heating	5
Thermal bridging	6
Fire performance	6
Environmental	7
Storage	7
Handling	7
Site working practice	7
Installation procedures	8
Insulation below concrete slab	8
Insulation below screed	10
Insulation between suspended timber joists / floors	11
Insulation in block and beam floors	12

Introduction

This guide has been prepared to assist designers and installers to ensure that PIR insulation products, when properly installed, work to their optimum ability in use. It does not supersede or replace product specific advice and/or guidance given by manufacturers, but is complementary to that advice/guidance.

The floor in any building is a key area of downward heat loss if not properly insulated. The use of PIR insulation can significantly improve the U-value of both new and existing floors in domestic and non-domestic properties. High performing PIR insulation boards are thinner than traditional insulation materials, therefore the need for deeper excavations is reduced, saving both time and money. PIR insulation boards are lightweight and easy to install and combine high compressive strength with low thermal conductivity, making them an ideal choice for all floor insulation projects.

Floor insulation types

PIR insulation is suitable for installation in a wide variety of floor applications. This guide looks at the four most widely used applications which are:

- below concrete slabs
- below floor screed
- insulation between battens under a timber floor
- block and beam

PIR insulation can also be used as insulation:

- below a floating timber floor
- below a floating chipboard floor
- in a suspended timber floor – installed from above floor joists
- in a suspended timber floor – installed from below the floor joists

For installation guidance on these types of floor insulation, please refer to the guidance from individual manufacturers.

Design considerations

General

When choosing a PIR board for a floor insulation project, care should be taken to ensure:

- That the product is suitable for the intended application (check the individual manufacturer's data sheet).
- The product carries the CE mark which means that it meets the requirements of BS EN 13165.
- The product may also be covered by a third party certificate such as one from the British Board of Agreement.
- That the product chosen is manufactured by a member of IMA (check the IMA website www.insulationmanufacturers.org.uk).

U-values

Always refer to individual manufacturer's literature to see how their products will assist in meeting the requirements of any national building regulations. All U-value calculations should be project-specific to take into account the performance characteristics of all materials being used and all IMA manufacturers offer a calculation service, undertaken in accordance with the principles of BR443 and other applicable standards, and in some cases under the Competent Person Scheme operated by the BBA.

Perimeter area ratio (P/A)

The P/A (perimeter area) ratio, together with details about the construction of the floor can be used to calculate the amount and thickness of insulation required to comply with the building regulations. The P/A ratio is a measure of the degree to which the perimeter of the floor is exposed: **$P/A = \text{exposed perimeter (m)} / \text{floor area (m}^2\text{)}$**

The lower the P/A ratio, the better the thermal performance of the floor. The floor area is calculated from the internal surfaces of the external walls, and includes all heated spaces, but not unheated spaces that are outside of the insulated body of the building.

Refer to information from individual insulation manufacturers to determine the amount of their insulation required for a given P/A ratio and floor type.

Under floor heating

When under floor heating is being used it is advised that floors should be highly insulated for optimum performance of the heating system. U-values of around 0.15 W/m²K should be considered.

The advice of the under floor engineer should be consulted before installation of the insulation, particularly when installed below a slab.

Comparison of thicknesses of typical floor insulation products with an R value of 4.5

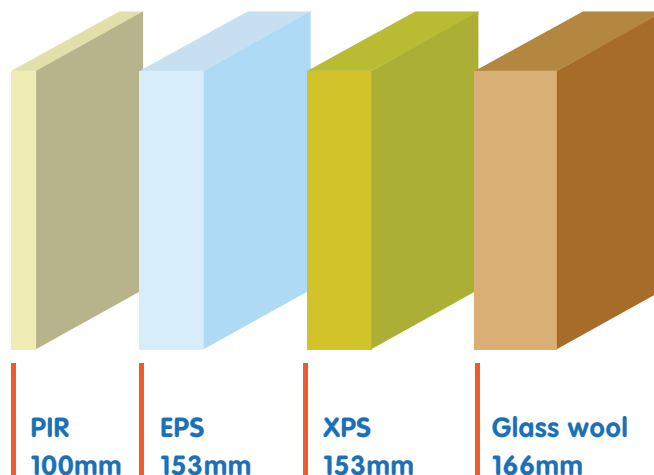

Thermal bridging

Linear thermal bridging is the heat loss that occurs at junctions between two, or more, construction elements. This is in addition to the heat losses through the primary elements of the construction, i.e. wall, floors, and roofs. The correct installation of PIR boards is essential to ensure continuity of the insulation layer with adjacent building elements. This means careful detailing at junctions between elements (e.g. floor/wall) to minimise the effects of thermal bridging. Advice should be sought from the manufacturer if required, some of whom have standard details highlighting installation best practice and heat loss measurements represented by Psi-Values (ψ).

Each design should be assessed individually. If no account of junction details is taken in energy assessments such as SAP or SBEM calculations, improved fabric performance (i.e. even lower U-values) will generally be required to offset the likely heat loss due to thermal bridging.

To limit losses through thermal bridging in flooring applications, a key consideration is the continuity of insulation at the wall to floor junction. Commonly a perimeter upstand of insulation is installed to increase the distance heat must pass through to escape at the junction. The low thermal conductivities and ease of installation make PIR insulation an ideal solution for these scenarios.

For further guidance on reducing thermal bridging Accredited Construction Details (ACDs) and Enhanced Construction Details (ECDs) have been developed to assist the construction industry achieve the performance levels required to aid compliance with the energy efficiency requirements of Approved Document Part L England and Wales, Section 6 of the Scottish Technical Handbook) and Technical Booklets F1 and F2 for Northern Ireland.

The excellent thickness to thermal performance ratio of PIR allows for thermal bridging detailing with minimal insulation thicknesses.

Fire performance

The product will be contained within the floor by the overlay until the overlay itself is destroyed. Therefore, the product will not contribute to the development stages of a fire. For further information on each individual product refer to manufacturer's literature, declarations of performance, and / or any third party approval such as third party certification.

Environmental

All PIR insulation boards produced by members of IMA are manufactured with a blowing agent that is CFC/HCFC free and has zero Ozone Depletion Potential (ODP) with a low Global Warming Potential (GWP).

Many manufacturers' products achieve a Green Guide rating of A+ but nevertheless PIR insulation has a generic Green Guide 2008 rating of A, making it one of the best environmentally performing insulation products available. Guidance on specific products should be sought from the manufacturer.

Storage

Insulation boards should be stored dry, flat and clear of the ground. Only as much material as can be installed during a single working period should be removed from storage at any one time. If boards are stored under tarpaulins, care should be taken to prevent rope damage to boards.

Boards should be stored away from any ignition hazards. Any stack of insulation boards should be stable with adequate access space provided between stacks of product.

Handling

- Take care when handling boards and do not drop them.
- Wear eye protection when cutting boards.
- Do not use damaged boards.
- It is recommended that gloves are worn when handling the product.
- Use a sharp knife or fine tooth saw to cut the boards.

Cutting with power tools generates non-hazardous dust, so should be kept to a minimum. Ideally all operations which produce dust should be carried out in well ventilated conditions; where possible a dust mask selected in accordance with BS EN 149 should be worn.

Site working practice

At the completion of each day's work, or whenever work is interrupted for extended periods of time, board edges and joints should be protected from inclement weather.

Installation procedures

Insulation below concrete slab

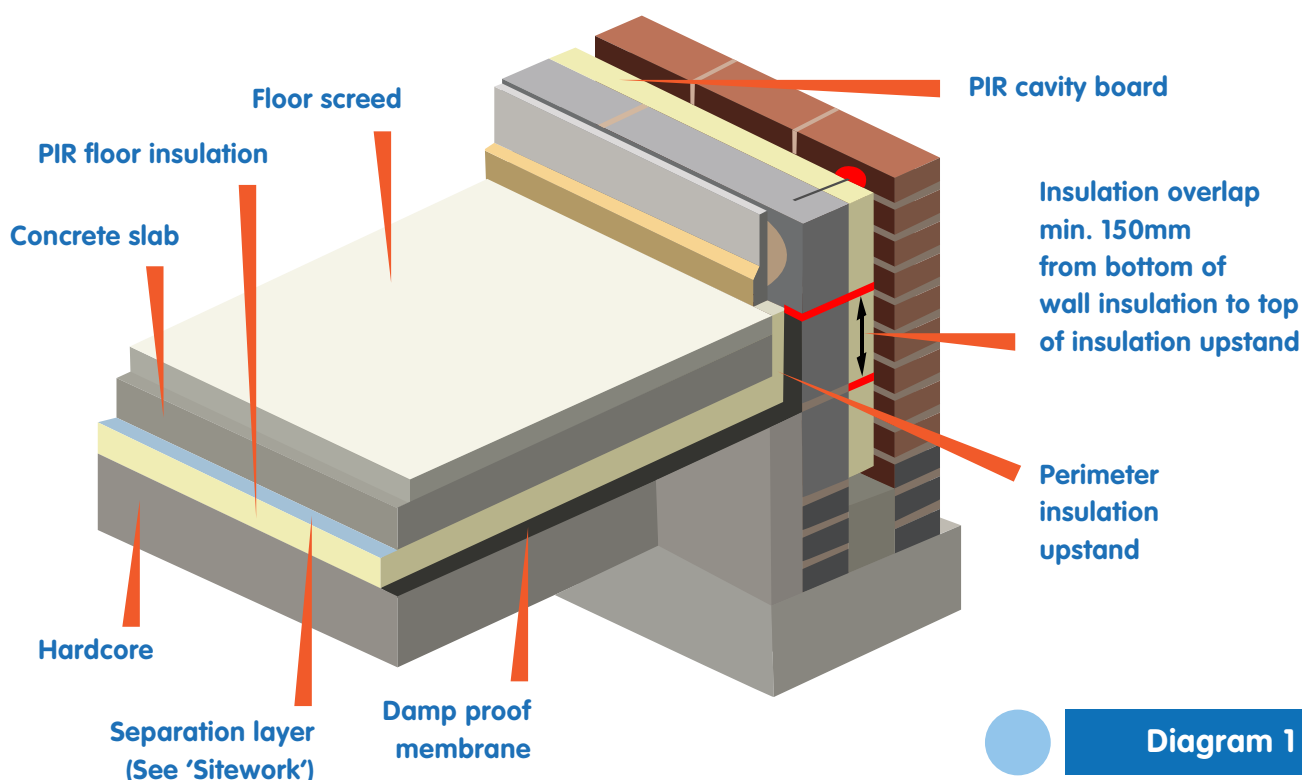

- Lay, level and compact the hardcore in layers (usually 150mm min / 250mm max).
- Apply sand-blind base (this base should be level to within 5mm along any 3m straight edge).
- Lay the damp proof membrane (DPM) (normally 1200g polythene sheet/300g micron or a radon barrier if specified), over the sand-blind base.
- Tape any lapped joints to prevent passage of ground moisture. Extend the DPM up to connect with the damp proof course (DPC).
- Lay the PIR board boards across the DPC, laid in a tightly butted brick bond pattern as shown in diagram 2.

If two insulation layers are needed to achieve the desired performance, the board joints should be staggered with the thicker layer positioned outermost.

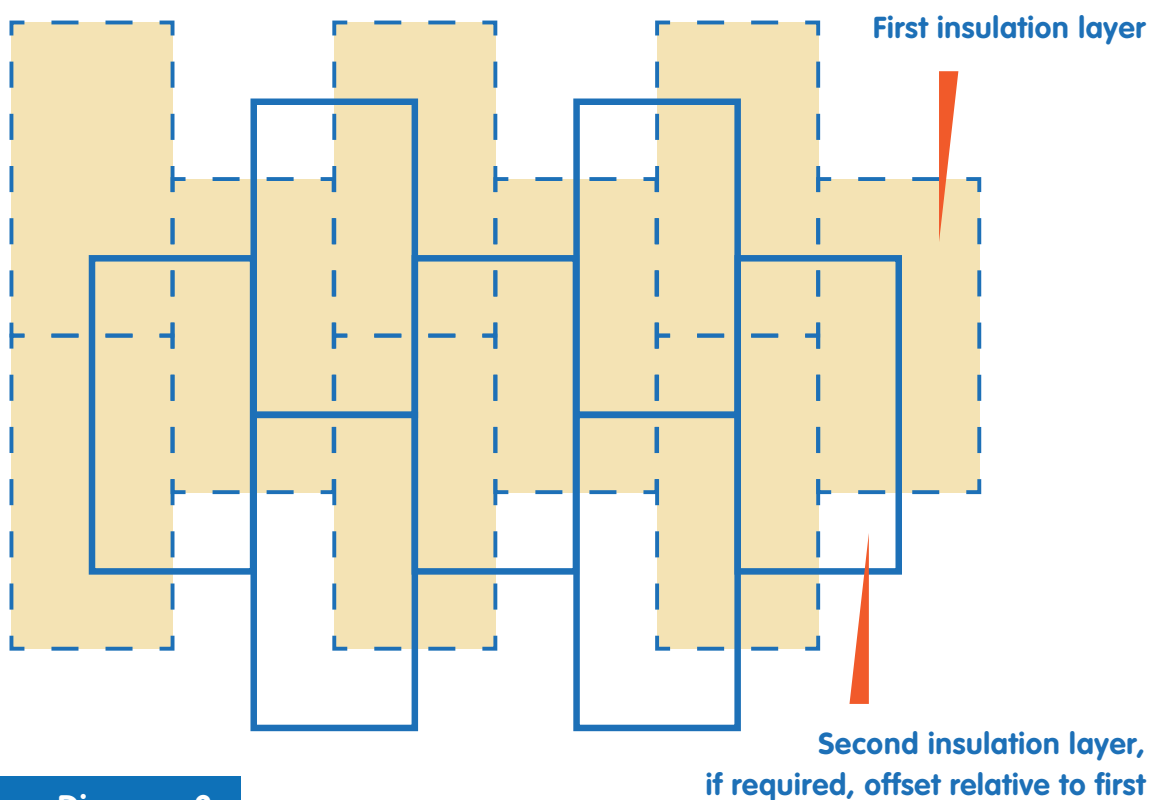
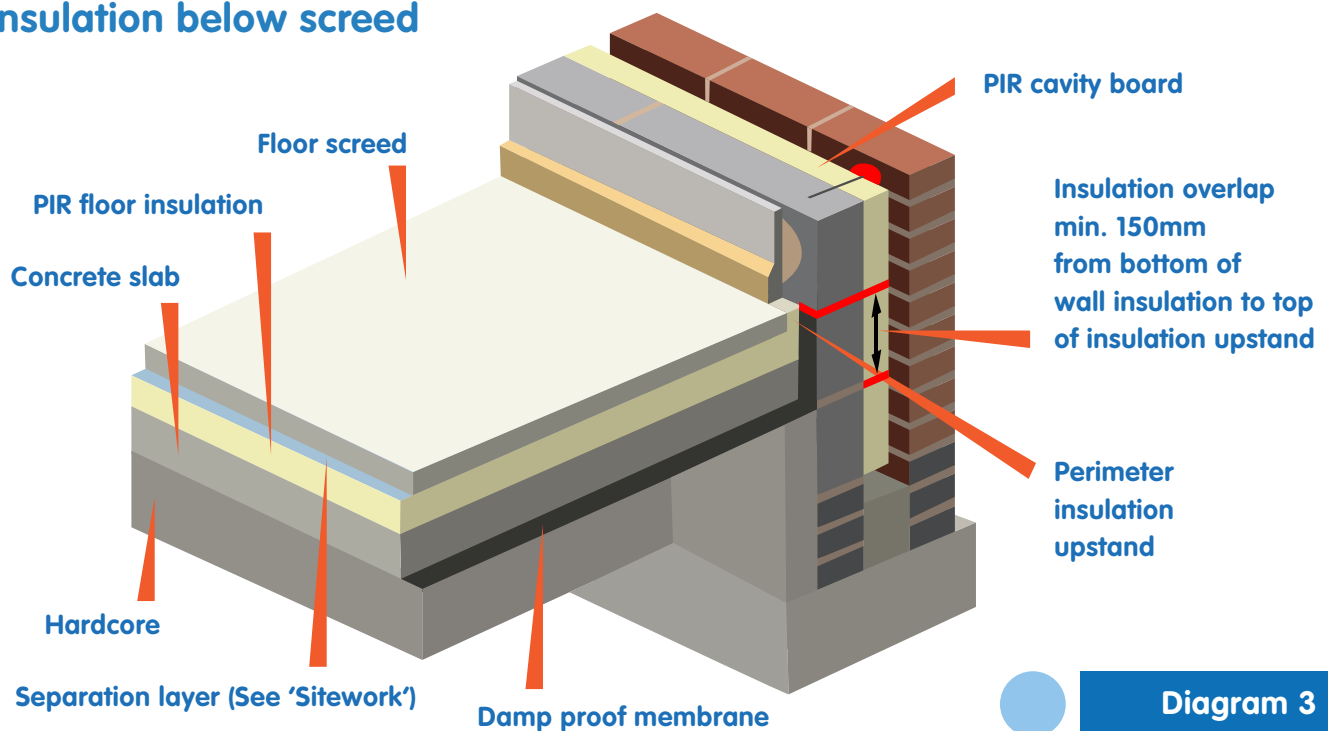

Diagram 2

- Use either strips of PIR insulation (minimum 20mm) cut to the slab depth, or pre-manufactured perimeter strips, to provide edge insulation.
- Overlay the PIR insulation with a polythene sheet (minimum 500 micron gauge) to act as a vapour control layer (VCL) and protect the insulation boards from the concrete.
- Overlaps should be minimum 150mm with taped joints.
- If underfloor heating is being installed, this should be done in accordance with the heating system design and supplier's instructions.
- Pour and compact the concrete slab in the normal manner.

Insulation below screed



- Pour and compact the concrete slab in the normal manner.
- Allow the slab to dry as fully as possible prior to continuing – the normal rate is one day for every millimetre of floor slab.
- Pre-cast systems or block & beam floors should be installed in accordance with manufacturer’s instructions. A thin levelling screed or grout may be required to ensure the base is level.
- Lay the damp proof membrane (DPM) (normally 1200g polythene sheet/300g micron (or a radon barrier if specified), either above or below the concrete with suitably lapped and taped joints to prevent the passage of ground moisture. Extend the DPM up to connect with the damp proof course (DPC).
- Lay the PIR boards across the DPM, laid in a tightly butted brick bond pattern as shown in diagram 1.
- If two insulation layers are needed to achieve the desired performance, the board joints should be staggered with the thicker layer positioned outermost on the cold side of the construction.
- Overlay the PIR insulation with a polythene sheet (minimum 500 micron gauge) to act as a vapour control layer (VCL) and protect the insulation boards from the concrete.
- Use a sand and cement screed to finish. The minimum thickness of screed to prevent cracking is 65mm for domestic applications and 75mm for other applications.
- Other high-performance screeds are available on the market. If these are used refer to the manufacturer’s instructions.

Insulation between suspended timber joists / floors

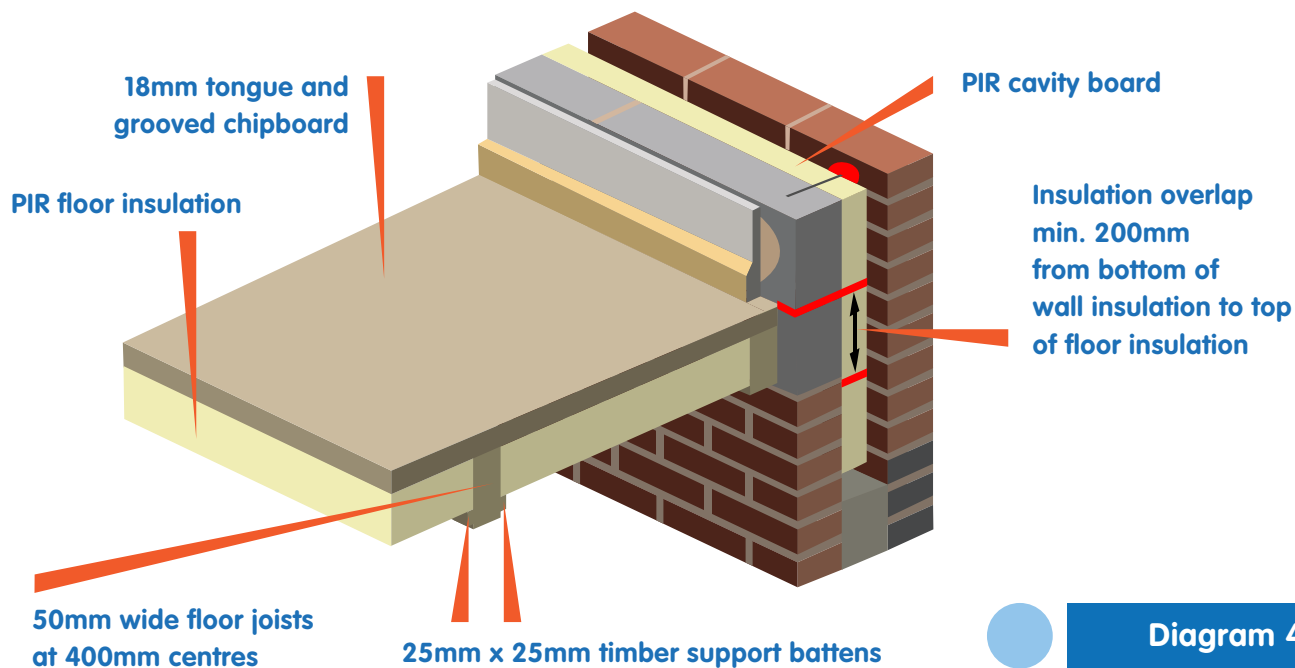

- Prior to floor boarding, the installation of the PIR insulation should take place.
- The insulation boards should fit tightly between the timber floor joists. As exact spacings between the floor joists can vary, measurements should be taken and boards then cut to size.
- Insulation boards should be supported on minimum 25mm x 25mm treated softwood timber battens, proprietary metal clips, or galvanised nails driven partially into the side of the joists. These supports should be fitted at suitable heights to the thickness of the board being fitted.
- The insulation boards should be fitted onto the supports, tightly between the timber floor joists, and with joints tightly butted. If two layers of insulation are required then the joints of these boards should be offset in order to avoid the joints of both layers coinciding with each other.
- In areas where there are minor gaps between the joists and insulation an expanding urethane sealant should be applied.
- Narrow gaps between the perimeter wall and the timber floor joists above 25mm should be insulated with specially cut pieces of PIR Insulation. These must be adequately supported as per the guidance above. Any gaps below 25mm should be filled with an expanding urethane sealant.

Insulation in block and beam floors

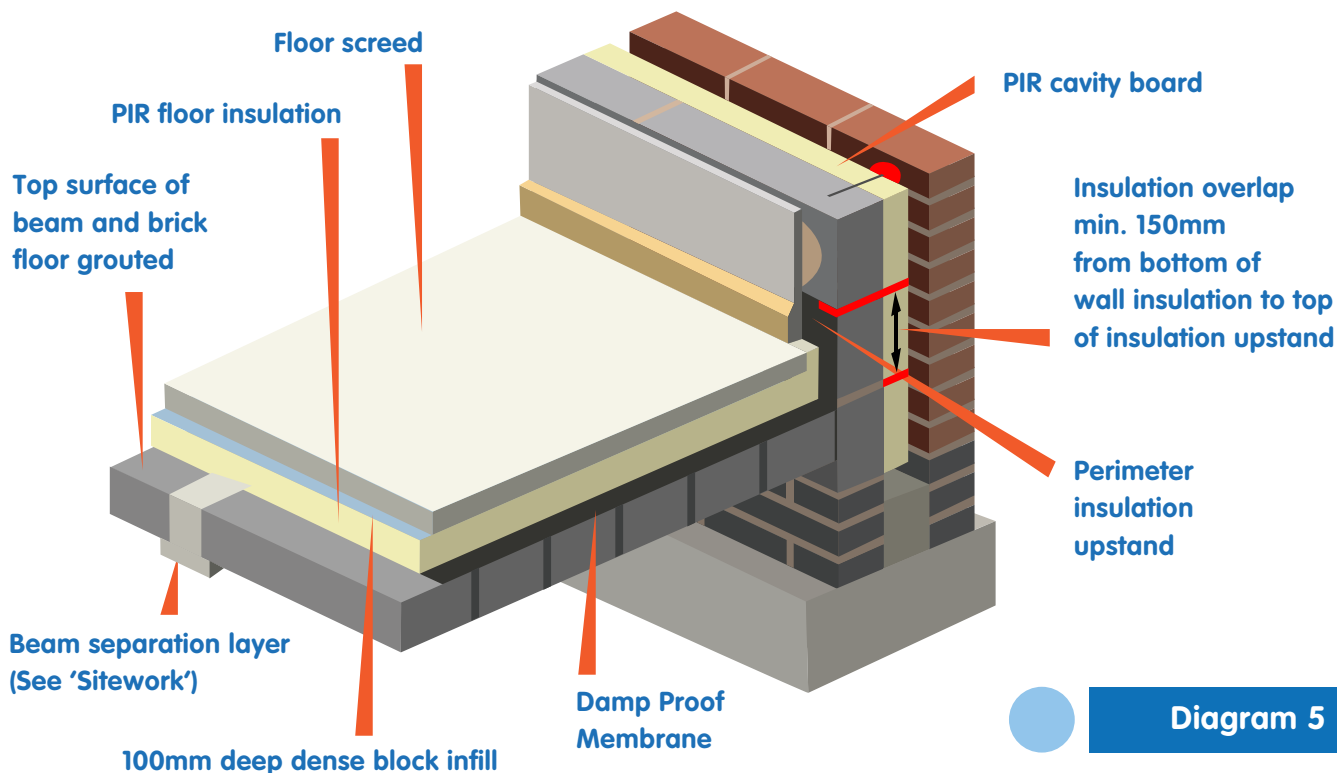

- If appropriate, lay a damp proof membrane (DPM) (normally 1200g polythene sheet/300g micron), to the top surface of the beam and block floor. Level the surface of the floor; it should be smooth and free of projections. Use a thin layer of sand-blinding to ensure that the insulation boards are continuously supported if required.
- Cut and fit insulation upstand to floor perimeter equal to the sum of the slab insulation and the screed thickness. The upstand thickness should not exceed the combined thickness of the wall linings.
- Lay the insulation boards directly onto the prepared beam and block floor with closely-butted, staggered cross-joints. Lay a polythene vapour control layer (VCL) over the insulation to minimise the risk of condensation forming at the insulation/slab interface and to prevent liquid screed migration. This separating layer will also prevent any reaction between the wet screed and foil facing of the insulation board. The VCL should be turned up at the edge of the floor to run up the surface of the upstand insulation to finish level with this and the top of screed. It is recommended good practice that all joints should be lapped 150mm and sealed.
- Apply a sand/cement or self-levelling screed over the insulation boards to a minimum thickness of 65mm.

For more details on the benefits of PIR insulation please visit: insulationmanufacturers.org.uk



Registered Office:
Units 10-12 County End Business Centre
Jackson Street
Oldham, OL4 4TZ